

Freeze-Pak™ STS

Secondary Shipping Containers



- » Designed for use with Freeze-Pak™ STS biocontainers
- » Flexible and durable design for frozen storage and transport
- » Single-use



Standard Applications

- » Frozen storage and transport for temperatures as low as -80°C

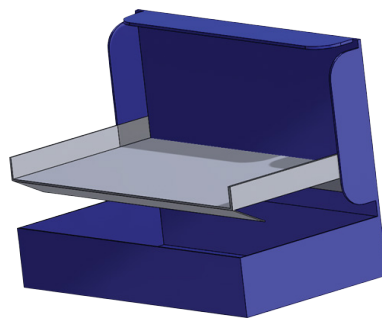

STS-XS

- » Dimensions (fully-assembled):
 - » 19.6" L x 11.8" W x 4.75" D
 - » 49.8 cm x 29.8 cm x 12.1 cm
- » Materials:
 - » Case: polypropylene plastic corrugate; blue
 - » Insert: folding polypropylene plastic corrugate with polyurethane film

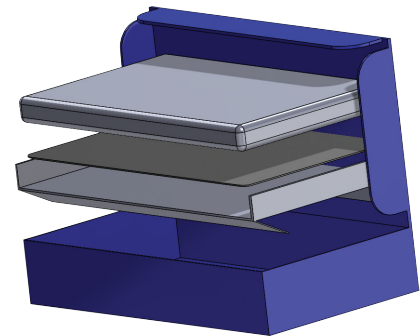

STS-XL

- » Dimensions (fully-assembled):
 - » 26.8" L x 15" W x 4.9" D
 - » 68.1 cm x 38.1 cm x 12.4 cm
- » Materials:
 - » Case: polypropylene plastic corrugate; blue
 - » Insert: folding polypropylene plastic corrugate with polyurethane film
 - » Sliding tray/pad: 5mm polypropylene plastic corrugate
 - » Foam pad: Formed Instapak

Ordering Information

Catalog #	Description	Case Qty.
STS-XS	Single-use, fully assembled secondary container, intended for Freeze-Pak™ STS bags up to 1L	5
STS-XL	Single-use, fully assembled secondary container, intended for Freeze-Pak™ STS bags up to 5L	5



Freeze Pak™ is a trademark of Charter Medical, Ltd.

All data and statements concerning these products may be considered as being indicative of representative properties and characteristics obtainable. We make no warranty, express or implied, concerning actual use or results because of industry specific influences.

